

CENTRE FOR RURAL ENERGY
GANDHIGRAM RURAL INSTITUTE - Deemed to be University
(Re Accredited with Grade "A" by NAAC)

Gandhigram – 624 302

Dindigul District, Tamil Nadu, India.

Tel: 0451-2452371-76: Extn. 2062

Fax: 0451- 2454466, 2453071

CRE/Furniture/2019

08.03.2019

Quotation Call for

For and on behalf of Gandhigram Rural Institute – Deemed to be University, Gandhigram quotations are invited for the supply of following equipment as per the specification below:

Code	Equipment
CREF01	Computer Table
CREF02	Work Bench
CREF03	Steel Almirah
CREF04	Vertical Filing Cabinet
CREF05	Notice Board

The terms and conditions for the quotations are as below:

- (i) Print TIN / GST or Registration Number in the quotation submission letter.
- (ii) The rate should clearly indicate the unit/nos.
- (iii) The rate should specify whether it includes duties and taxes land also packing and forwarding charges.
- (iv) If the rates are exclusive of the items mentioned against(ii) above the rate at which these items will be charges should also be specified wherever possible
- (v) The period upto the materials/equipments are guaranteed should be specified. The amount chargeable as Annual Maintenance charges after the guarantee / warranty period should be indicated separately.
- (vi) The nearest service point should also be indicated in the offer.
- (vii) The offer should be as far as possible from ready stock.
- (viii) Where the offer is not from ready stock, the period before which supply will be affected should be indicated.
- (ix) The mode of payment should be specified.
- (x) Payment will be made within a week from the date of receipt of materials and duty certified by the officers concerned / with in a week of the satisfactory completion of the work.
- (xi) Validity of the offer should normally be for 30 days from the date of offer. If otherwise, the period should be specifically mentioned.
- (xii) Quotation should be addressed in the name of
“**Registrar**, Gandhigram Rural Institute – Deemed to be University, Gandhigram”
and should be sent in a sealed envelope super scribing “**Quotation for Furniture**” : Item Code CREF _____”
to reach the following address:
The Director
Centre for Rural Energy
Gandhigram Rural Institute – Deemed to be University
Gandhigram – 624 302, Dindigul Dt.
- (xiii) **Hard Copy of Quotation will be received (By Post / In Person) up to 3.00 p.m. on 15.03.2019**
- (xiv) Quotation will be opened at 4.00 p.m. on the same day in the presence of the Representatives of the firms who are available.

CREF01 COMPUTER TABLE

Specification

Table Size	36" L x 21" W x 30" H or more
Material	To be made with pre-laminated medium density board 18mm thick and edges sealed with PVC edge banding .
Features	Sliding key board with channel(24" x 18" or nearest), Sliding platform for printer (24" x18" or nearest std.), a drawer (12" W x 6" H x 20" D), and a place for CPU with auto hinge cover. Table base should have Castor wheels for smooth movement of system .
Color	Natural finish
Load Capacity	30kg or more

CREF02 WORK BENCH

Specification

Material : Wood
Purpose : Wooden, Steel and Electrical Work

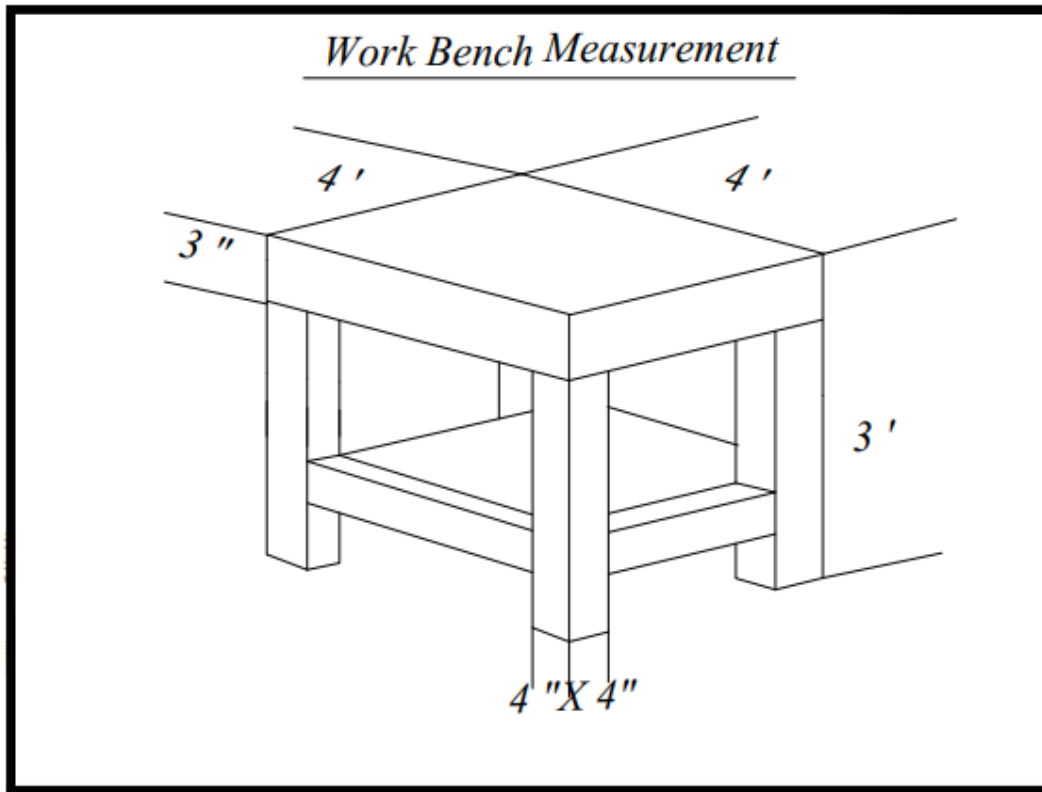

CREF03 STEEL ALMIRAH

Size 1980mm(H)x900mm(W)x480mm(D)

Sheet Thickness 22 gauge for body and 20 gauge for doors.

The Almirah should have four shelves making five compartments of standard size. The doors of almirah provided with stiffeners made of MS sheet spot welded to the doors. The almirah equipped with a special three way bolting device with tongue-in groove inter locking mechanism with six lever lock. The handle made from a non ferrous metal alloy, chrome plated. The complete almirah duly painted with synthetic enamel paint of approved shade in and outside.

CREF04 VERTICAL FILING CABINET

Heights 1320mm

Widths 470mm

Draw heights to fit standard suspension files.

CREF05 NOTICE BOARD

Size : 4 feet * 3 Feet
Color : Green
Door : Glass with lock